



# UNISIG

## DEEP HOLE DRILLING SOLUTIONS FOR MEDICAL MANUFACTURERS



HIGH-PRECISION  
GUNDRILLING MACHINES



MEDICAL-SPECIFIC SMALL  
DIAMETER GUNDRILLING

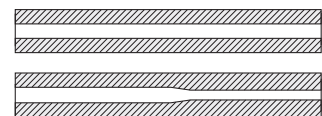

DESIGNED FOR DEEP HOLES IN  
MEDICAL TOOLING AND COMPONENTS

## Precise, efficient solutions for medical component manufacturers.

At UNISIG, we understand the unique barriers you face making medical components.

- Small dimensions with extreme depth-to-diameter ratios
- Workpieces made of tough materials with thin walls
- Prohibitively slow production due to order-of-operation or aggressive tolerances
- Skilled labor is difficult to find, and automation is underutilized



## Why UNISIG

UNISIG has nearly 40 years of experience delivering precise, intuitive deep hole drilling machines around the globe. We collaborate with our customers to understand their industry-specific needs - from small job shops to multi-billion-dollar OEMs. We then apply our engineering expertise to go beyond the limits of what our customers thought was possible.

Our hands-on experience with medical components has driven us to understand the challenges within the industry - and we stand by our customers throughout the entire process. We don't just sell machines. We create systems that enable our customers to achieve greater success.

***“The process collaboration with UNISIG gave us confidence that we could produce our part and hold the runout. The team at UNISIG evaluated our process and demands. And they made it happen.”***





# UNISIG Gundrilling Solutions for Medical Applications

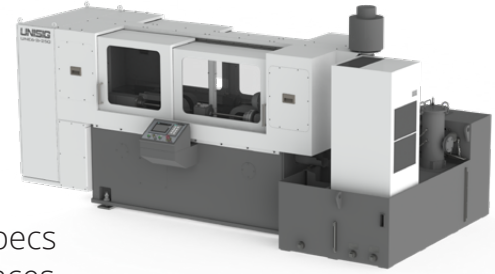

Change the way you approach medical manufacturing and take advantage of what UNISIG machines can do. With superior alignment, precision and specs designed around your needs, you can confidently hold concentricity tolerances and minimize mismatch. UNISIG machines do more than drill a hole. They give you the ability to increase throughput and accuracy, and open up possibilities for the entire way you produce your critical parts.

## Integrated Solutions for Medical Applications

Medical manufacturers can lean on UNISIG's expertise and process collaboration, ensuring that they confidently understand and utilize the full capabilities of their system upon installation.

## Optimized Productivity

Maximize your production by adding a UNISIG gundrilling machine to your Swiss turning cells, significantly improving your throughput while upholding accuracy standards.



## Expand Capability Efficiently and Ergonomically

Configurations designed to maximize production include an independent spindle set-up for the ultimate in manufacturing flexibility, with operators or robotics.



## Gundrill with Accuracy and Repeatability

Flow-based coolant, a precision-aligned machine platform, workpiece-specific clamping, and operational temperature control allow operators to hit tight tolerances, every time.

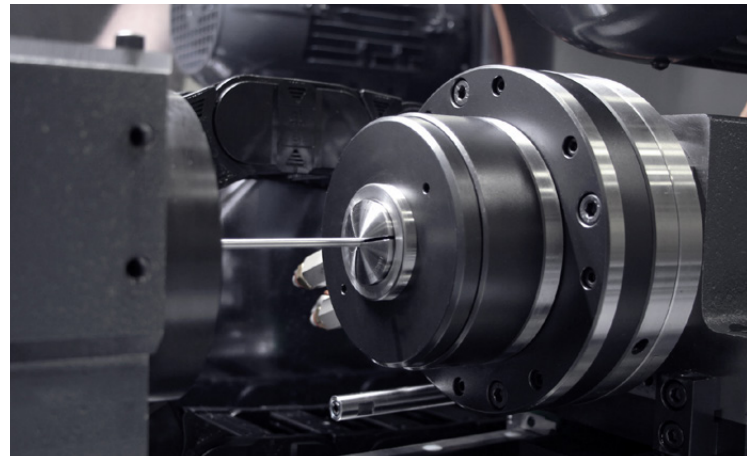

## Minimize Financial Risk

When you can gundrill your turned parts with confidence, you increase your standards while also controlling costs, compared with purchasing cannulated materials.

## UNE6 Machine Systems

### Features | All UNE6 Models

#### Configured specifically for medical industry components

- Counter-rotating tool and workpiece
- Specialized workholding for small parts
- Exceptional process control

#### Superior mechanical design efficiency

- Precision machine alignment
- Preloaded, high-stiffness ballscrews
- Integral motor spindles
- Simple 3-point leveling installation

#### Flow-based coolant system

- Programmable flow delivery puts exactly the right amount of coolant to the cutting edge
- Coolant pumps provide up to 3,000 psi for the smallest, deepest holes
- Tool breakage is detected immediately regardless of tool size

#### Smart control interface

- Intuitive, informative operation
- Program storage for repeatable production

#### Independent Spindle Configuration

Dual independent spindles expand manufacturing capabilities

- Spindle set-up for stepped bores or increased production
- Independent setup and programming per spindle
- Compact installation with select shared systems
- Operation configuration for 1 - 2 operators, or operator + robot

## UNE6 Models

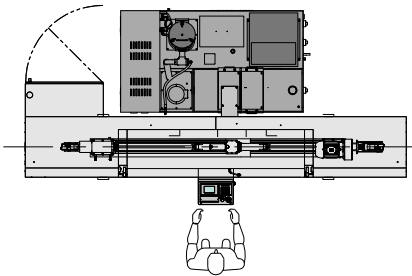

### UNE6

The single spindle machine allows sequential operations to be run in batches, or with multiple machines in a cell. Robot-ready configuration with automatic doors and part sensing are available as options.

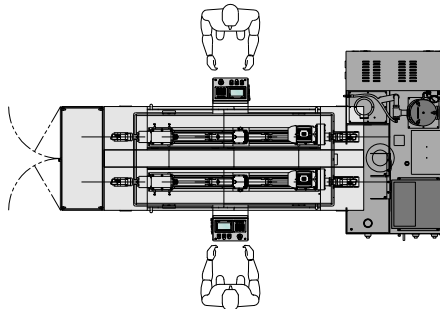

### UNE6-2i

A dual spindle, independent machine offers separate working zones on each side. Different operations or parts can run on the same machine, accessible from the front and rear.

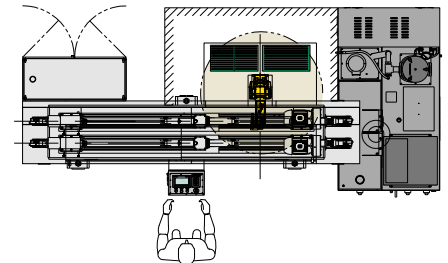

### UNE6-2i

A dual spindle, independent machine offers a single operating zone for operator loading. Sequential operations can be run on the same machine. Optional robotic automation from the rear is available without interfering manual set-up and operation.

## Specifications

DIMENSION	UNE6		UNE6-2i	
Number of spindles	1		2 independent	
Hole diameter minimum	0.8 mm	0.03 in	0.8 mm	0.03 in
Hole diameter maximum	6.0 mm	0.24 in	6.0 mm	0.24 in
Part length maximum	750 mm	30 in	250 or 750 mm	10 or 30 in
Tool spindle speed maximum	19,000 rpm		19,000 rpm	
Work spindle speed maximum	4,000 rpm		4,000 rpm	
Combined drilling speed maximum	23,000 rpm		23,000 rpm	
Coolant pressure maximum	207 bar	3,000 psi	207 bar	3,000 psi



FIND FULL PRODUCT DETAILS, VIDEOS,  
AND TECHNICAL INFORMATION ONLINE

[www.unisig.com](http://www.unisig.com)